

Filament wound pipe – pipe type E

System:	Vinyl ester resin
Pressure range:	up to 6 bar
Temperature:	max. 90°C
Chemical barrier:	2,5 mm Chemical barrier
Standard:	in dependence on DIN 16965 part 5
Connection type:	plain ends for lamination

Pipe type E in dependence on DIN 16965 part 5
2,5 mm Chemical barrier

Description: Pipe type E
 System: Vinyl ester resin
 Connection: plain ends
 Standard: DIN 16 965 Part 5
 Diameter: DN 25 - 500
 Pressure class: PN 4, PN 6

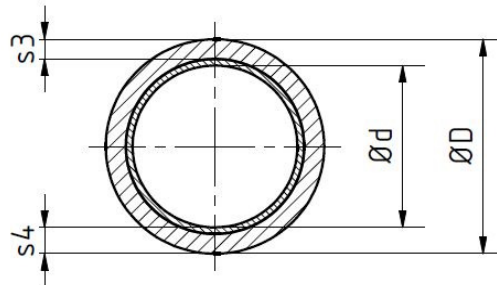

DN	PN4					PN6				
	$\varnothing D$	$\varnothing d$	S4	S3	weigh t	$\varnothing D$	$\varnothing d$	S4	S3	weigh t
[mm]	[mm]	[mm]	[mm]	[mm]	[kg/m]	[mm]	[mm]	[mm]	[mm]	[kg/m]
25										
40										
50										
65										
80										
100										
125						135	125	5,0	2,5	3,3
150						160	150	5,0	2,5	3,9
200						211	200	5,6	3,1	6,2
250	260	250	5,0	2,5	6,4	263	250	6,7	4,2	9,0
300	311	300	5,5	3,0	8,4	316	300	7,9	5,4	12,4
350	363	350	6,3	3,8	11,6	368	350	9,0	6,5	16,2
400	414	400	7,1	4,6	13,4	420	400	10,1	7,6	21,7
500	517	500	8,6	6,1	23,0	529	500	14,7	12,2	32,2

Pipe type E in dependence on DIN 16965 part 5
2,5 mm Chemical barrier

Description: Pipe type E
 System: Vinyl ester resin
 Connection: plain ends
 Standard: DIN 16 965 Part 5
 Diameter: DN 25 - 500
 Pressure class: PN10, PN16

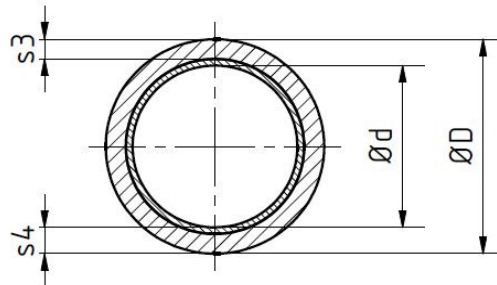

DN	PN10					PN16				
	$\varnothing D$	$\varnothing d$	S4	S3	weigh t	$\varnothing D$	$\varnothing d$	S4	S3	weigh t
[mm]	[mm]	[mm]	[mm]	[mm]	[kg/m]	[mm]	[mm]	[mm]	[mm]	[kg/m]
25						35	25	5,0	2,5	0,8
40						50	40	5,0	2,5	1,1
50						60	50	5,0	2,5	1,4
65	75	65	5,0	2,5	1,8	75	65	5,1	2,6	2,0
80	90	80	5,0	2,5	2,1	92	80	6,1	3,6	2,8
100	110	100	5,0	2,5	2,6	115	100	7,3	4,8	4,1
125	137	125	5,9	3,4	4,0	143	125	8,9	6,4	6,1
150	164	150	6,8	4,3	5,5	171	150	10,5	8,0	8,5
200	218	200	8,7	6,2	9,5	227	200	13,6	11,1	15,1
250	272	250	70,7	68,2	14,4	284	250	16,8	14,3	22,8
300	326	300	12,6	10,1	20,4	340	300	19,9	17,4	32,2
350	379	350	14,5	12,0	26,6	396	350	23,1	20,6	44,1
400	433	400	16,4	13,9	34,5	452	400	26,2	23,7	56,8
500	541	500	20,3	17,8	53,6	565	500	32,5	30,0	87,0

Elbow 90° PN 10 Pipe type E

Description: Elbow 90°
 Connection: plain ends
 System: Vinyl ester resin
 Diameter: DN 25 - 500
 Pressure class: PN 10

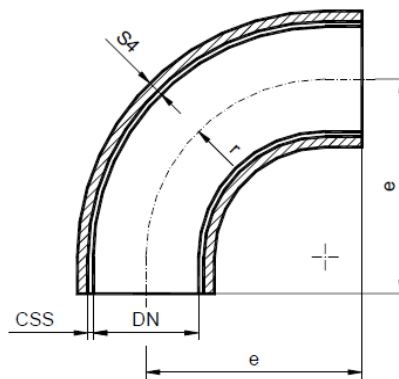

DN [mm]	S4 [mm]	e [mm]	r [mm]	CSS [mm]
25	5,0	110	80	2,5
40	5,0	150	120	2,5
50	5,0	180	165	2,5
65	5,0	140	125	2,5
80	5,0	165	125	2,5
100	5,0	205	170	2,5
125	5,0	245	210	2,5
150	5,4	285	215	2,5
200	6,4	365	320	2,5
250	7,3	450	390	2,5
300	8,3	525	440	2,5
350	9,2	600	600	2,5
400	10,1	680	670	2,5
450	11,1	820	620	2,5
500	12,0	830	650	2,5

Elbow 90° PN 16 Pipe type E

Description: Elbow 90°
 Connection: plain ends
 System: Vinyl ester resin
 Diameter: DN 25 - 500
 Pressure class: PN 16

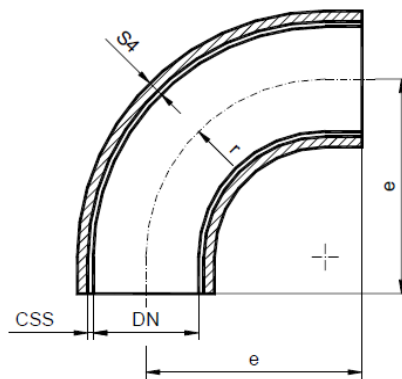

DN [mm]	S4 [mm]	e [mm]	r [mm]	CSS [mm]
25	5,0	110	80	2,5
40	5,0	150	120	2,5
50	5,0	180	165	2,5
65	5,0	140	125	2,5
80	5,1	165	125	2,5
100	5,7	205	170	2,5
125	6,5	245	210	2,5
150	7,3	285	215	2,5
200	8,8	365	320	2,5
250	10,4	450	390	2,5
300	11,9	525	440	2,5
350	13,5	600	600	2,5
400	15,0	680	670	2,5
450	16,6	820	620	2,5
500	18,1	830	650	2,5

Tee PN 10 Pipe type E

Description: Tee
 Connection: plain ends
 System: Vinyl ester resin
 Diameter: DN 25 – 400
 Pressure class: PN 10

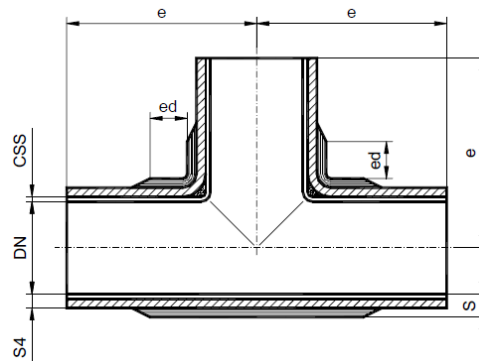

DN [mm]	S4 [mm]	S [mm]	e [mm]	ed [mm]	CSS [mm]
25	5,0	6,25	110	50	2,5
40	5,0	6,25	150	50	2,5
50	5,0	6,25	180	50	2,5
65	5,0	6,25	140	50	2,5
80	5,0	6,25	165	50	2,5
100	5,0	6,25	205	50	2,5
125	5,0	6,25	145	70	2,5
150	5,4	6,85	285	70	2,5
200	6,4	8,20	365	70	2,5
250	7,3	9,55	450	120	2,5
300	8,3	10,90	525	120	2,5
350	9,2	12,55	600	120	2,5
400	10,1	13,75	680	120	2,5

Tee PN 16 Pipe type E

Description: Tee
 Connection: plain ends
 System: Vinyl ester resin
 Diameter: DN 25 - 400
 Pressure class: PN 16

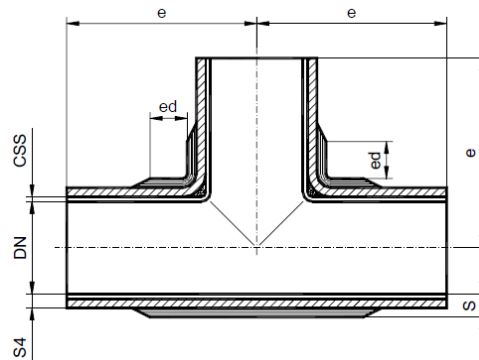

DN [mm]	S4 [mm]	S [mm]	e [mm]	ed [mm]	CSS [mm]
25	5,0	6,25	110	50	2,5
40	5,0	6,25	150	50	2,5
50	5,0	6,25	180	50	2,5
65	5,0	6,25	140	50	2,5
80	5,0	6,40	165	50	2,5
100	5,0	7,30	205	50	2,5
125	5,0	8,35	145	70	2,5
150	5,4	9,55	285	70	2,5
200	6,4	11,80	365	70	2,5
250	7,3	14,10	450	120	2,5
300	8,3	16,30	525	120	2,5
350	9,2	18,55	600	120	2,5
400	10,1	20,80	680	120	2,5

Concentric reducer PN 10 Pipe type E

Description: Concentric reducer 22°
 Connection: plain ends
 System: Vinyl ester resin
 Diameter: DN 25 – 600
 Pressure class: PN 10

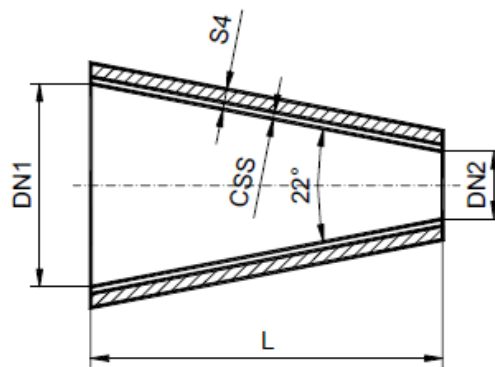

DN1 [mm]	DN2 [mm]	S4 [mm]	L [mm]	CSS [mm]
40	25	5,0	39,0	2,5
50	25	5,0	64,0	2,5
50	40	5,0	26,0	2,5
65	40	5,0	64,0	2,5
65	50	5,0	39,0	2,5
80	40	5,0	103,0	2,5
80	50	5,0	77,0	2,5
80	65	5,0	39,0	2,5
100	50	5,0	129,0	2,5
100	65	5,0	90,0	2,5
100	80	5,0	51,0	2,5
125	65	5,0	154,0	2,5
125	80	5,0	116,0	2,5
125	100	5,0	64,0	2,5
150	80	5,4	180,0	2,5
150	100	5,4	129,0	2,5
150	125	5,4	64,0	2,5
200	100	6,4	257,0	2,5
200	125	6,4	193,0	2,5
200	150	6,4	129,0	2,5
250	125	7,3	322,0	2,5

DN1 [mm]	DN2 [mm]	S4 [mm]	L [mm]	CSS [mm]
250	150	7,3	257,0	2,5
250	200	7,3	129,0	2,5
300	150	8,3	386,0	2,5
300	200	8,3	257,0	2,5
300	250	8,3	129,0	2,5
350	200	9,2	386,0	2,5
350	250	9,2	257,0	2,5
350	300	9,2	129,0	2,5
400	250	10,1	386,0	2,5
400	300	10,1	257,0	2,5
400	350	10,1	129,0	2,5
450	300	11,1	386,0	2,5
450	350	11,1	257,0	2,5
450	400	11,1	129,0	2,5
500	350	12,0	386,0	2,5
500	400	12,0	257,0	2,5
500	450	12,0	129,0	2,5
600	400	13,9	514,0	2,5
600	450	13,9	386,0	2,5
600	500	13,9	257,0	2,5

Concentric reducer PN 16 Pipe type E

Description: Concentric reducer 22°
 Connection: plain ends
 System: Vinyl ester resin
 Diameter: DN 25 – 600
 Pressure class: PN 16

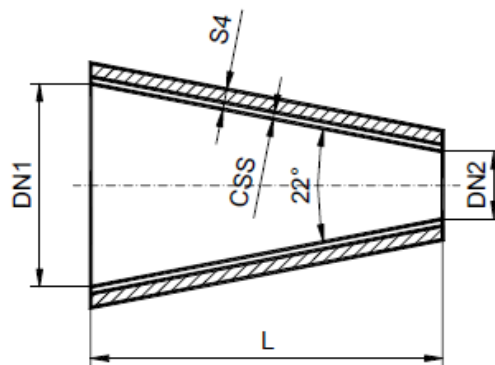

DN1 [mm]	DN2 [mm]	S4 [mm]	L [mm]	CSS [mm]
40	25	5,0	39	2,5
50	25	5,0	64	2,5
50	40	5,0	26	2,5
65	40	5,0	64	2,5
65	50	5,0	39	2,5
80	40	5,1	103	2,5
80	50	5,1	77	2,5
80	65	5,1	39	2,5
100	50	5,7	129	2,5
100	65	5,7	90	2,5
100	80	5,7	51	2,5
125	65	6,5	154	2,5
125	80	6,5	116	2,5
125	100	6,5	64	2,5
150	80	7,3	180	2,5
150	100	7,3	129	2,5
150	125	7,3	64	2,5
200	100	8,8	257	2,5
200	125	8,8	193	2,5
200	150	8,8	129	2,5
250	125	10,4	322	2,5

DN1 [mm]	DN2 [mm]	S4 [mm]	L [mm]	CSS [mm]
250	150	10,4	257	2,5
250	200	10,4	129	2,5
300	150	11,9	386	2,5
300	200	11,9	257	2,5
300	250	11,9	129	2,5
350	200	13,5	386	2,5
350	250	13,5	257	2,5
350	300	13,5	129	2,5
400	250	15,0	386	2,5
400	300	15,0	257	2,5
400	350	15,0	129	2,5
450	300	16,5	386	2,5
450	350	16,6	257	2,5
450	400	16,6	129	2,5
500	350	18,1	386	2,5
500	400	18,1	257	2,5
600	400	21,2	514	2,5
600	450	21,2	386	2,5
600	500	21,2	257	2,5

Eccentric reducer PN 10 Pipe type E

Description: Eccentric reducer 22°
 Connection: plain ends
 System: Vinyl ester resin
 Diameter: DN 40 – 500
 Pressure class: PN 10

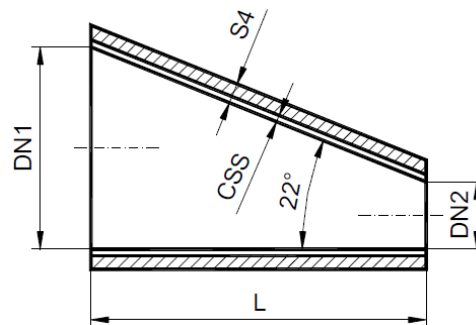

DN1 [mm]	DN2 [mm]	S4 [mm]	L [mm]	CSS [mm]
50	40,0	5,0	25	2,5
65	40,0	5,0	62	2,5
65	50,0	5,0	37	2,5
80	40,0	5,0	99	2,5
80	50,0	5,0	74	2,5
80	65,0	5,0	37	2,5
100	50,0	5,0	124	2,5
100	65,0	5,0	87	2,5
100	80,0	5,0	50	2,5
125	65,0	5,0	149	2,5
125	80,0	5,0	11	2,5
125	100,0	5,0	62	2,5
150	80,0	5,4	173	2,5
150	100,0	5,4	124	2,5
150	125,0	5,4	62	2,5
200	100,0	6,4	248	2,5
200	125,0	6,4	186	2,5
200	150,0	6,4	124	2,5
250	125,0	7,3	309	2,5
250	150,0	7,3	248	2,5
250	200,0	7,3	124	2,5
300	150,0	8,3	371	2,5
300	200,0	8,3	248	2,5
300	250,0	8,3	124	2,5
350	200,0	9,2	371	2,5
350	250,0	9,2	248	2,5

DN1 [mm]	DN2 [mm]	S4 [mm]	L [mm]	CSS [mm]
350	300,0	9,2	124	2,5
400	250,0	10,1	371	2,5
400	300,0	10,1	248	2,5
400	350,0	10,1	124	2,5
450	300,0	11,1	371	2,5
450	350,0	11,1	248	2,5
450	400,0	11,1	124	2,5
500	350,0	12,0	371	2,5
500	400,0	12,0	248	2,5

Eccentric reducer PN 16 Pipe type E

Description: Eccentric reducer
 Connection: plain ends
 System: Vinyl ester resin
 Diameter: DN 40 – 500
 Pressure class: PN 16

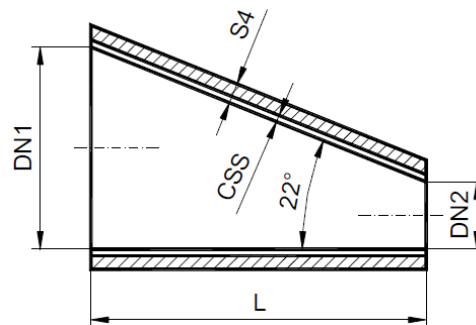

DN1 [mm]	DN2 [mm]	S4 [mm]	L [mm]	CSS [mm]
50	40	5,0	25	2,5
65	40	5,0	62	2,5
65	50	5,0	37	2,5
80	40	5,1	99	2,5
80	50	5,1	74	2,5
80	65	5,1	37	2,5
100	50	5,7	124	2,5
100	65	5,7	87	2,5
100	80	5,7	50	2,5
125	65	6,5	149	2,5
125	80	6,5	11	2,5
125	100	6,5	62	2,5
150	80	7,3	173	2,5
150	100	7,3	124	2,5
150	125	7,3	62	2,5
200	100	8,8	248	2,5
200	125	8,8	186	2,5
200	150	8,8	124	2,5
250	125	10,4	309	2,5
250	150	10,4	248	2,5
250	200	10,4	124	2,5
300	150	11,9	371	2,5
300	200	11,9	248	2,5
300	250	11,9	124	2,5
350	200	13,5	371	2,5
350	250	13,5	248	2,5

DN1 [mm]	DN2 [mm]	S4 [mm]	L [mm]	CSS [mm]
350	300	13,5	124	2,5
400	250	15,0	371	2,5
400	300	15,0	248	2,5
400	350	15,0	124	2,5
450	300	16,5	371	2,5
450	350	16,6	248	2,5
450	400	16,6	124	2,5
500	350	18,1	371	2,5
500	400	18,1	248	2,5

Fix flange PN 10 Pipe type E

Description: formed fix flange
 Connection: Connection according DIN 2501 Part 1, PN 10
 System: Vinyl ester resin
 Diameter: DN 25 - 500
 Pressure class: PN 10

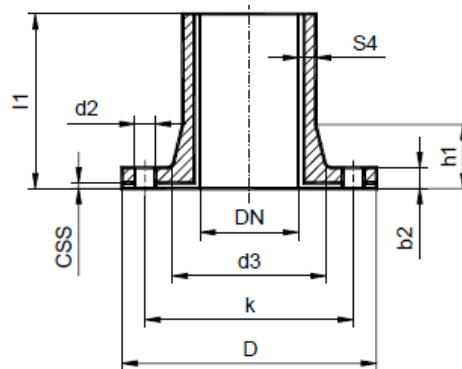

DN [mm]	S4 [mm]	D [mm]	d3 [mm]	k [mm]	d2 [mm]	b2 [mm]	h1 [mm]	l1 [mm]	CSS [mm]
25	5,0	115	50	85	14	14	30	150	2,5
40	5,0	150	68	110	18	17	35	150	2,5
50	5,0	165	82	125	18	17	40	150	2,5
65	5,0	185	95	145	18	19	44	150	2,5
80	5,0	200	111	160	18	19	48	150	2,5
100	5,0	220	133	180	18	20	55	150	2,5
125	5,0	250	160	210	18	21	64	200	2,5
150	5,4	285	188	240	18	23	71	200	2,5
200	6,4	340	245	295	22	24	85	200	2,5
250	7,3	395	300	350	22	28	101	250	2,5
300	8,3	445	350	400	22	34	116	250	2,5
350	9,2	505	410	460	22	34	133	300	2,5
400	10,1	565	460	515	26	42	147	300	2,5
450	11,1	615	511	565	26	44	120	350	2,5
500	12,0	670	565	620	26	52	178	350	2,5

Fix flange PN 16 Pipe type E

Description: formed fix flange
 Connection: Connection according DIN 2501 Part 1, PN 10
 System: Vinyl ester resin
 Diameter: DN 25 - 500
 Pressure class: PN 16

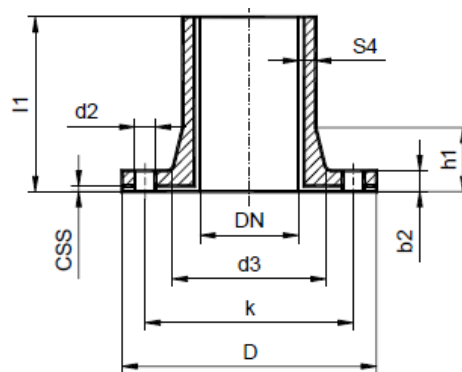

DN [mm]	S4 [mm]	D [mm]	d3 [mm]	k [mm]	d2 [mm]	b2 [mm]	h1 [mm]	l1 [mm]	CSS [mm]
25	5,0	115	50	85	14	17	30	150	2,5
40	5,0	150	68	110	18	20	35	150	2,5
50	5,0	165	82	125	18	21	40	150	2,5
65	5,0	185	95	145	18	23	44	150	2,5
80	5,0	200	111	160	18	24	48	150	2,5
100	5,0	220	133	180	18	24	55	150	2,5
125	5,0	250	160	210	18	27	64	200	2,5
150	5,4	285	188	240	18	30	71	200	2,5
200	6,4	340	245	295	22	36	85	200	2,5
250	7,3	395	300	350	22	42	101	250	2,5
300	8,3	445	350	400	22	49	116	250	2,5
350	9,2	505	410	460	22	56	133	300	2,5
400	10,1	565	460	515	26	63	147	300	2,5
450	11,1	615	511	565	26	69	120	350	2,5
500	12,0	670	565	620	26	76	178	350	2,5

Collar PN 10 Pipe type E

Description: formed collar
 Connection: Connection according DIN 2501 Part 1, PN 10
 System: Vinyl ester resin
 Diameter: DN 25 - 500
 Pressure class: PN 10

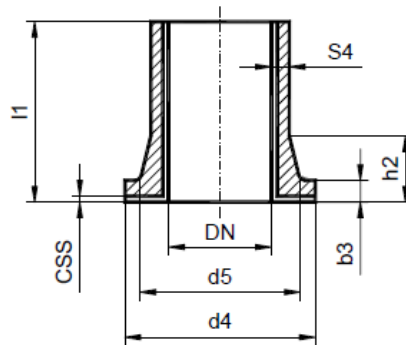

DN [mm]	S4 [mm]	d4 [mm]	d5 [mm]	b3 [mm]	h2 [mm]	l1 [mm]	CSS [mm]
25	5,0	68	50	12	30	150	2,5
40	5,0	88	68	14	35	150	2,5
50	5,0	102	82	14	40	150	2,5
65	5,0	122	95	14	44	150	2,5
80	5,0	138	111	14	48	150	2,5
100	5,0	158	133	15	55	150	2,5
125	5,0	188	160	16	64	200	2,5
150	5,4	212	188	17	71	200	2,5
200	6,4	268	237	18	85	200	2,5
250	7,3	320	293	19	101	250	2,5
300	8,3	370	343	20	116	250	2,5
350	9,2	430	387	40	133	300	2,5
400	10,1	482	441	43	147	300	2,5
450	11,1	538	499	43	160	350	2,5
500	12,0	585	544	53	178	350	2,5

Collar PN 16 Pipe type E

Description: formed collar
 Connection: Connection according DIN 2501 Part 1, PN 10
 System Vinyl ester resin
 Diameter: DN 25 - 500
 Pressure class: PN 16

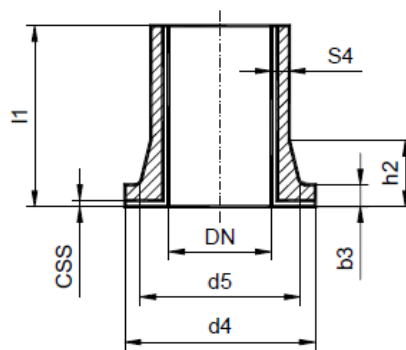

DN	S4	d4	d5	b3	h2	l1	CSS
[mm]	[mm]	[mm]	[mm]	[mm]	[mm]	[mm]	[mm]
25	5,0	68	50	12	30	150	2,5
40	5,0	88	68	14	35	150	2,5
50	5,0	102	82	14	40	150	2,5
65	5,0	122	95	14	44	150	2,5
80	5,0	138	111	14	48	150	2,5
100	5,0	158	133	15	55	150	2,5
125	5,0	188	160	18	64	200	2,5
150	5,4	212	188	18	71	200	2,5
200	6,4	268	237	30	85	200	2,5
250	7,3	320	293	32	101	250	2,5
300	8,3	370	343	40	116	250	2,5
350	9,2	430	387	56	133	300	2,5
400	10,1	482	441	61	147	300	2,5
450	11,1	538	499	64	160	350	2,5
500	12,0	585	544	73	178	350	2,5

Loose flange compressed Pipe type E

Description: GRP-loose flange
 Connection: Connection according DIN 2501 Part 1, PN 10
 System: Vinyl ester resin
 Diameter: DN 25 – 500
 Pressure class: from PN 6 till PN 16 (see table)

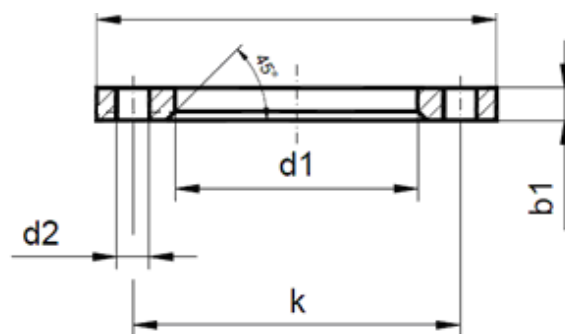

DN [mm]	PN [bar]	D [mm]	d1 [mm]	k [mm]	d2 [mm]	b1 [mm]	No.	Bolts
25	16	115	50,5	85	14	14	4	M12
40	16	150	68,5	110	18	16	4	M16
50	16	165	82,5	125	18	18	4	M16
65	10	185	95,5	145	18	20	4	M16
80	10	200	111,5	160	18	22	8	M16
100	10	220	133,5	180	18	24	8	M16
125	10	250	160,5	210	18	27	8	M16
150	10	285	188,5	240	22	30	8	M20
200	6	340	238	295	22	32	8	M20
250	6	395	294	350	22	34	12	M20
300	6	445	344	400	22	3	12	M20
350	4	505	388	460	22	38	16	M20
400	4	656	442	515	26	42	16	M24
500	4	670	545	620	26	47	20	M24

Steel loose flange PN 10
Pipe type E

Description: Steel loose flange
 Connection: Connection according DIN 2501 Part 1, PN 10
 Diameter: DN 25 – 500
 Pressure class: PN 10

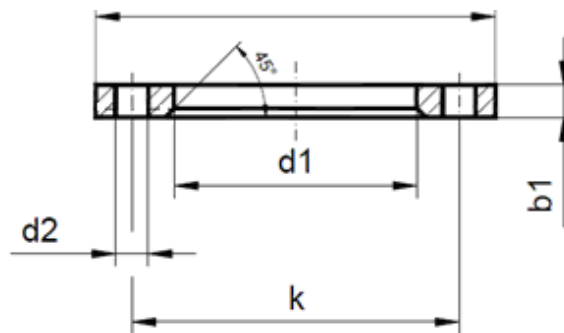

DN [mm]	D [mm]	d1 [mm]	k [mm]	d2 [mm]	b1 [mm]	No.	Bolts
25	115	50,5	85	14	16	4	M12
40	150	68,5	110	18	16	4	M16
50	165	82,5	125	18	16	4	M16
65	185	95,5	145	18	16	4	M16
80	200	111,5	160	18	18	8	M16
100	220	133,5	180	18	18	8	M16
125	250	160,5	210	18	18	8	M16
150	285	188,5	240	22	18	8	M20
200	340	238	295	22	20	8	M20
250	395	294	350	22	22	12	M20
300	445	344	400	22	26	12	M20
350	505	388	460	22	28	16	M20
400	656	442	515	26	32	16	M24
450	615	500	565	26	35	20	M24
500	670	545	620	26	38	20	M24