

## RED THREAD II

<b>System:</b>	Epoxy resin
<b>Pressure range:</b>	DN 50 - DN 150 up to 31 bar DN 250 - DN 500 up to 16 bar
<b>Temperature:</b>	up to 100°C
<b>Chemical barrier:</b>	highly resinous inner layer of 0,2 mm
<b>Connection type:</b>	T.A.B. (Threaded and Bonded) DN 25-DN 150

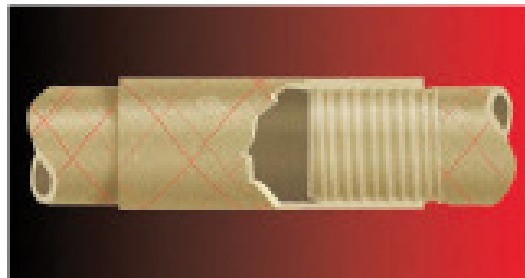

Socket and spigot for bonding  
DN 150-DN 500



## Red Thread II

Description: Red Thread II  
 Connection: DN 50 - DN 150 T.A.B.  
                   DN 200 - DN 500 socket/spigot  
 Standard: ISO Dimensions  
 Diameter: DN 50 - 500  
 Pressure class: PN 16

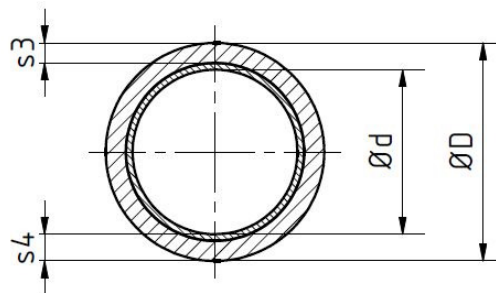

Diameter DN	$\varnothing D$ [mm]	$s4$ [mm]	$\varnothing d$ [mm]	$s3$ [mm]	Pipe volume [l/m]	Type / socket length	Weight [kg/m]
50	61	2,0	57	1,8	2,6	T.A.B.	0,6
80	90	2,0	85	1,8	5,7	T.A.B.	1,0
100	115	2,5	111	2,3	9,7	T.A.B.	1,8
150	170	3,4	163	3,2	20,9	T.A.B.	3,5
200	219	3,6	212	3,4	35,3	socket/spigot	4,9
250	273	4,8	263	4,6	54,3	socket/spigot	7,9
300	323	5,5	312	5,3	76,5	socket/spigot	10,7
350	370	6,8	356	6,6	99,5	socket/spigot	15,3
400	423	7,7	407	7,5	130,1	socket/spigot	19,8
450	469	8,1	453	7,9	161,2	socket/spigot	23,0
500	520	8,3	504	8,1	199,5	socket/spigot	26,0

Delivery length = 6 m.

## Elbow 90°

Description: Elbow 90°  
 Connection: cylindrical socket up to DN 500  
 System: Epoxy  
 Diameter: DN 25 - 500  
 Pressure class: PN 16 up to DN 300; PN 10 from DN 350 to DN 500

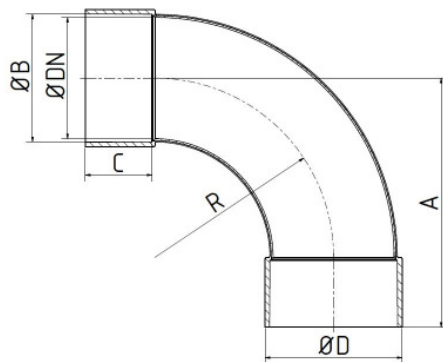

DN	ø D [mm]	ø B [mm]	R [mm]	C [mm]	A [mm]	Weight ca.[kg]
25	44	33,4	38	32,5	75,0	0,2
40	58	48,0	55	32,5	91,0	0,3
50	73	60,0	67	37,5	109,0	0,4
65	87	74,0	95	46,0	128,0	0,7
80	102	89,0	100	52,5	159,0	1,1
100	126	114,0	140	67,5	213,0	1,8
125	152	135,0	210	87,5	287,0	2,9
150	180	168,0	235	87,5	326,0	3,5
200	231	219,0	307	87,5	401,0	5,1
250	286	273,0	355	97,5	464,0	8,2
300	341	324,0	450	97,5	539,0	14,7
350	379	363,0	500	97,5	625,0	16,6
400	431	413,0	586	100,0	688,0	23,8
500	540	520,0	600	140,0	877,5	44,1

## Elbow 45°

Description: Elbow 45°  
 Connection: cylindrical socket up to DN 500  
 System: Epoxy  
 Diameter: DN 25 - 500  
 Pressure class: PN 16 up to DN 300; PN 10 from DN 350 to DN 500

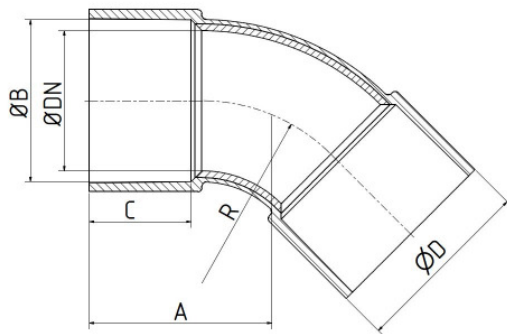

DN	ø D [mm]	ø B [mm]	R [mm]	C [mm]	A [mm]	Weight ca.[kg]
25	41	33,4	38	32,5	50	0,1
40	58	48,0	55	32,5	60	0,2
50	67	60,0	67	37,5	70	0,3
65	84	74,0	95	47,5	85	0,5
80	100	89,0	100	52,5	101	0,7
100	121	114,0	140	67,5	130	1,2
125	144	135,0	210	87,5	170	1,9
150	180	168,0	235	87,5	181	2,7
200	231	219,0	307	87,5	224	4,0
250	286	273,0	355	97,5	240	5,7
300	341	324,0	450	97,5	270	8,6
350	379	363,0	500	97,5	267	9,0
400	431	413,0	586	100,0	329	13,0
500	540	520,0	600	140,0	365	19,0

## Tee

Description: Tee  
 Connection: cylindrical socket up to DN 500  
 System: Epoxy  
 Diameter: DN 25 - 500  
 Pressure class: PN 16 up to DN 300; PN 10 from DN 350 to DN 500

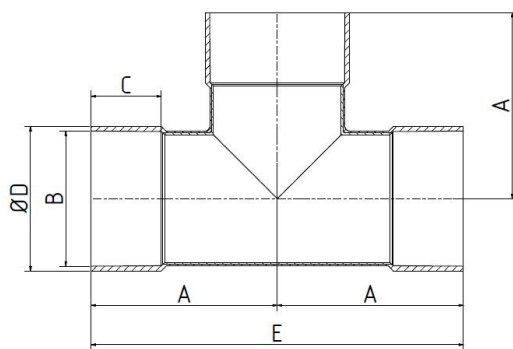

DN	ø D [mm]	ø B [mm]	C [mm]	A [mm]	E [mm]	Weight ca.[kg]
25	44	33,4	32,5	112	224	0,4
40	57	48,0	32,5	117	234	0,5
50	70	60,0	37,5	133	266	0,7
65	84	74,0	47,5,	140	280	1,3
80	100	89,0	52,5	158	316	1,5
100	124	114,0	67,5	184	368	2,3
125	144	134,5	87,5	255	510	3,2
150	180	168,0	87,5	232	464	4,3
200	235	219,0	87,5	312	624	8,4
250	295	273,0	97,5	384	768	14,1
300	345	324,0	97,5	410	820	15,8
350	385	363,0	97,5	550	1100	32,0
400	440	413,0	100,0	600	1200	54,0
500	540	520,0	140	650	1300	90,0

## Concentric reducer

Description: Concentric reducer  
 Connection: cylindrical socket up to DN 500  
 System: Epoxy  
 Diameter: DN 25 - 500  
 Pressure class: PN 16 up to DN 300; PN 10 from DN 350 to DN 500

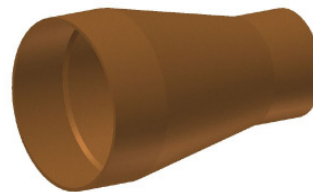
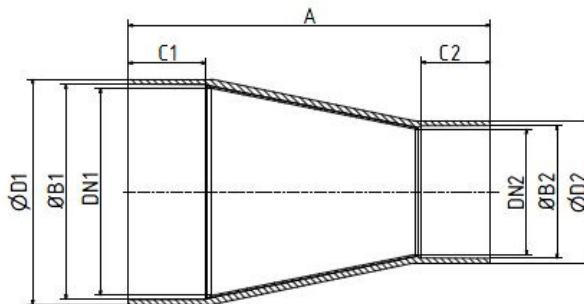

DN1	DN2	A [mm]	C1 [mm]	C2 [mm]	B1 [mm]	B2 [mm]	D1 [mm]	D2 [mm]	Weight ca. [kg]
40	25	110	32,5	32,5	48	33	57	45	0,2
50	25	140	37,5	32,5	60	33	70	45	0,2
50	40	100	37,5	32,5	60	48	70	57	0,2
65	40	145	47,5	32,5	74	48	90	57	0,4
65	50	135	47,5	37,5	74	60	90	70	0,4
80	40	200	52,5	32,5	89	48	100	57	0,4
80	50	175	52,5	37,5	89	60	100	70	0,4
80	65	150	52,5	47,5	89	74	100	90	0,5
100	40	264	67,5	32,5	114	48	122	57	0,6
100	50	245	67,5	37,5	114	60	122	70	0,7
100	65	205	67,5	47,5	114	74	122	90	0,8
100	80	180	67,5	52,5	114	89	122	97	0,9
150	80	330	87,5	52,5	168	89	180	97	1,7
150	100	294	87,5	67,5	168	114	180	122	1,5
150	125	245	87,5	87,5	168	135	180	144	1,3
200	100	420	87,5	67,5	219	114	231	122	2,6
200	125	250	87,5	87,5	219	135	231	144	2,4
200	150	315	87,5	87,5	219	168	231	180	2,2
250	150	455	97,5	87,5	273	168	286	180	4,8
250	200	330	97,5	87,5	273	219	286	231	3,2
300	150	585	97,5	87,5	324	168	340	180	7,5
300	200	460	97,5	87,5	324	219	340	231	5,0
300	250	350	97,5	97,5	324	273	340	286	3,7

## Concentric reducer

Description: Concentric reducer  
 Connection: cylindrical socket up to DN 500  
 System: Epoxy  
 Diameter: DN 25 - 500  
 Pressure class: PN 16 up to DN 300; PN 10 from DN 350 to DN 500

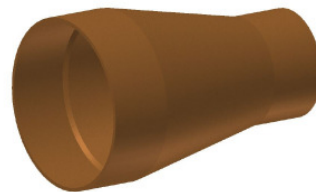
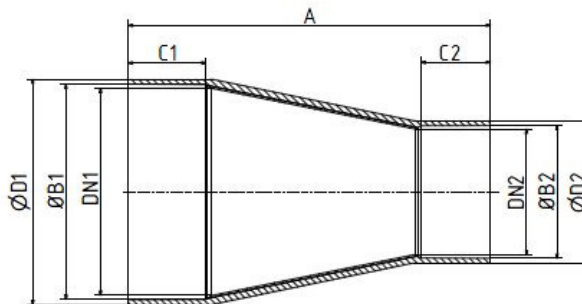

DN1	DN2	A [mm]	C1 [mm]	C2 [mm]	B1 [mm]	B2 [mm]	D1 [mm]	D2 [mm]	Weight ca. [kg]
350	250	465	97,5	97,5	363	273	377	286	3,5
350	300	342	97,5	97,5	363	324	377	286	6,0
400	300	470	100	97,5	413	324	430	340	10,5
400	350	340	100	97,5	413	363	430	377	8,0
500	300	755	130	97,5	520	324	540	340	16,0
500	400	490	130	100	520	413	540	430	13,5

## Eccentric reducer

Description: Eccentric reducer  
 Connection: cylindrical socket up to DN 500  
 System: Epoxy  
 Diameter: DN 25 - 500  
 Pressure class: PN 16 up to DN 300; PN 10 from DN 350 to DN 500

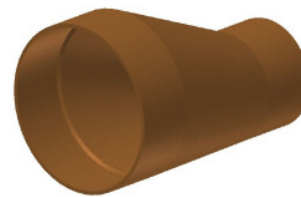
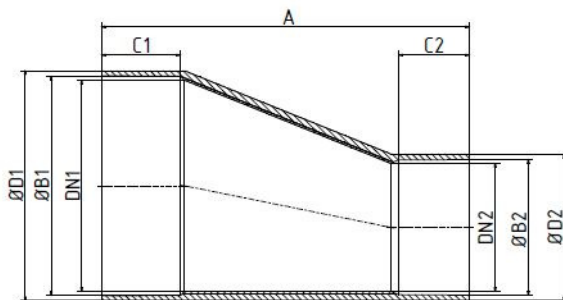

DN1	DN2	A [mm]	C1 [mm]	C2 [mm]	B1 [mm]	B2 [mm]	D1 [mm]	D2 [mm]	Weight ca. [kg]
40	25	110	32,5	32,5	48,0	33,4	57	45	0,2
50	25	140	37,5	32,5	60,0	33,4	70	45	0,2
50	40	100	37,5	32,5	60,0	48	70	57	0,3
65	40	145	47,5	32,5	74	48	90	57	0,4
65	50	135	47,5	37,5	74	60	90	70	0,4
80	40	200	52,5	32,5	89	48	100	57	0,7
80	50	175	52,5	37,5	89	60	100	70	0,7
80	65	150	52,5	47,5	89	74	100	90	0,5
100	40	264	67,5	32,5	114	48	122	57	0,7
100	50	245	67,5	37,5	114	60	122	70	0,6
100	65	205	67,5	47,5	114	74	122	90	0,8
100	80	180	67,5	52,5	114	89	122	97	0,6
150	80	330	87,5	52,5	168	89	180	97	2,2
150	100	294	87,5	67,5	168	114	180	122	1,2
150	125	245	87,5	87,5	168	135	180	144	1,3
200	100	420	87,5	67,5	219	114	231	122	1,9
200	125	250	87,5	87,5	219	135	231	144	2,4
200	150	315	87,5	87,5	219	168	231	180	3,0
250	150	455	97,5	87,5	273	168	286	180	5,0
250	200	330	97,5	87,5	273	219	286	231	4,2
300	150	585	97,5	87,5	324	168	340	180	6,5
300	200	460	97,5	87,5	324	219	340	231	4,4
300	250	350	97,5	97,5	324	273	340	286	4,1

## Eccentric reducer

Description: Eccentric reducer  
 Connection: cylindrical socket up to DN 500  
 System: Epoxy  
 Diameter: DN 25 - 500  
 Pressure class: PN 16 up to DN 300; PN 10 from DN 350 to DN 500

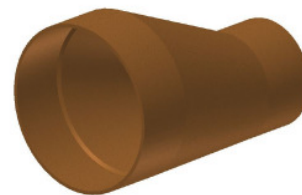
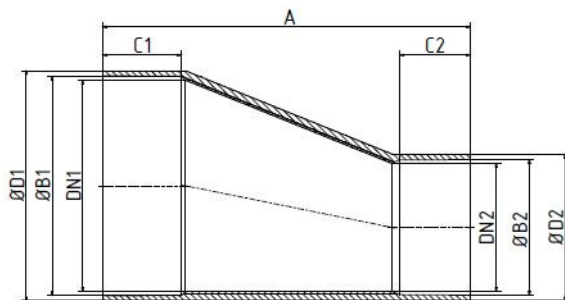

DN1	DN2 [mm]	A [mm]	C1 [mm]	C2 [mm]	B1 [mm]	B2 [mm]	D1 [mm]	D2 [mm]	Weight ca. [kg]
350	250	465	97,5	97,5	363	273	377	286	7,0
350	300	342	97,5	97,5	363	324	377	286	5,4
400	300	470	100	97,5	413	324	430	340	14,0
400	350	340	100	97,5	413	363	430	377	16,0
500	300	755	125	97,5	520	324	540	340	17,0
500	400	490	125	100	520	413	540	430	14,5

## Coupling

Description: Coupling  
 Connection: cylindrical bonding up to DN 500  
 System: Epoxy  
 Diameter: DN 25 - 500  
 Pressure class: PN 16 up to DN 300; PN 10 from DN 350 to DN 500

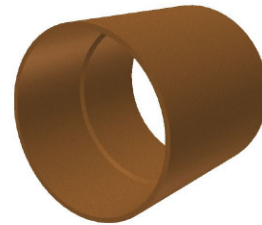
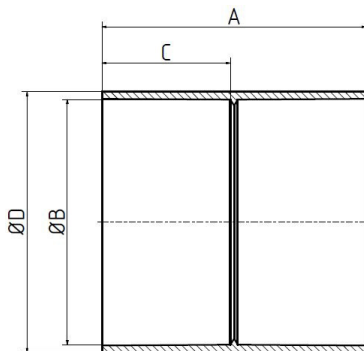

DN	ø D [mm]	ø B [mm]	C [mm]	A [mm]	Weight ca.[kg]
25	41	33,4	32,5	70	0,1
40	55	48,0	32,5	70	0,1
50	67	60,0	37,5	80	0,1
65	87	74,0	47,5	100	0,2
80	96	89,0	52,5	110	0,2
100	121	114,0	67,5	140	0,4
150	178	168,0	87,5	180	0,9
125	150	130,5	87,5	170	0,8
200	231	219,0	87,5	180	1,4
250	286	273,0	97,5	200	2,2
300	341	324,0	97,5	200	3,2
350	377	363,0	97,5	200	3,0
400	429	413,0	100,0	205	4,0
500	540	520,0	130,0	290	7,5

## Cap

Description: Cap  
 Connection: cylindrical socket up to DN 100  
 System: Epoxy  
 Diameter: DN 25 - 100  
 Pressure class: PN 16 up to DN 100

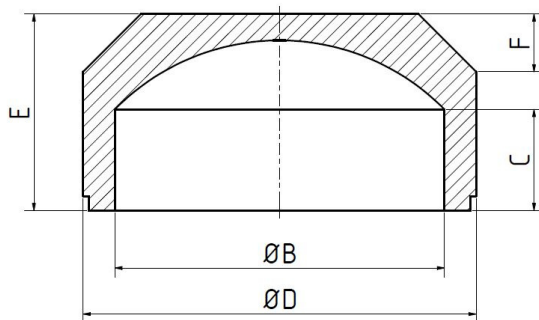

DN	ø D [mm]	ø B [mm]	C [mm]	E [mm]	F [mm]	Weight ca.[kg]
25	54	34	25	40	7	0,7
40	63	48	25	37	7	0,1
50	74	60	25	39	7	0,1
65	92	73	30	55	20	0,2
80	110	89	35	65	14	0,3
100	136	114	35	68	20	0,4

## Saddle

Description: Saddle with insert  
 Connection: cylindrical socket up to DN 300  
 System: Epoxy  
 Diameter: DN 25 - 300  
 Pressure class: PN 16 up to DN 300

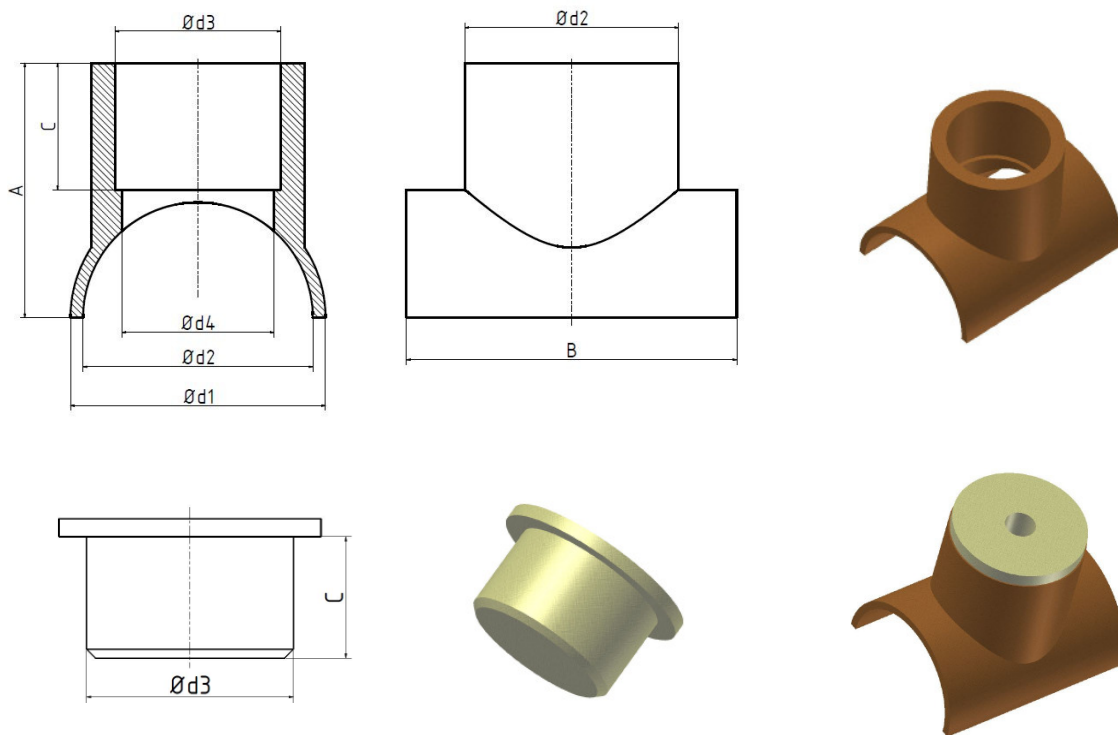

DN	Ø d1 [mm]	Ø d2 [mm]	Ø d3 [mm]	Ø d4 [mm]	A [mm]	B [mm]	C [mm]	Weight ca.[kg]
40	70	48,3	39,5	24,5	62	90	34	0,2
50	80	60,3	48,3	39,5	72	103	34	0,3
80	112	88,9	60,3	48,3	106	152	38	0,5
100	140	114,6	88,9	80,1	130	152	55	0,8
125	169	137,0	88,9	80,1	130	154	55	1,0
150	190	168,0	114,6	100,5	170	229	70	1,0
200	246	219,0	168,0	159,2	201	229	89	1,8
250	306	273,0	219,0	211,0	250	229	90	3,3
300	357	324,0	273,0	262,6	303	332	98	4,2

## Collar

Description: Collar  
 Connection: cylindrical socket up to DN 500  
 System: Epoxy  
 Diameter: DN 25 - 500  
 Pressure class: PN 16 up to DN 300; PN 10 from DN 350 to DN 500

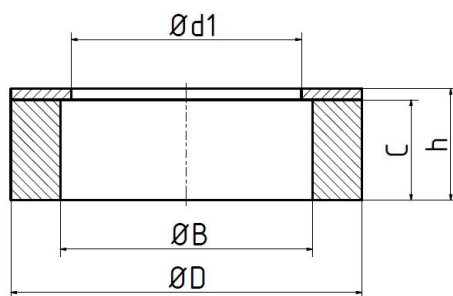

DN	$\varnothing D$ [mm]	$\varnothing d 1$ [mm]	$\varnothing B$ [mm]	C [mm]	h [mm]	Weight ca.[kg]
25	68	30	33,4	20	27,5	0,1
40	88	39	48,0	20	27,5	0,2
50	102	51	60,0	25	32,5	0,3
65	122	64	75,0	25	32,5	0,4
80	138	77	89,0	30	37,5	0,6
100	158	101	114,0	40	47,5	0,8
150	212	155	168,0	50	57,5	1,3
125	189	125	134,5	40	47,5	1,0
200	268	205	219,0	60	67,5	2,2
250	320	263	273,0	75	82,5	3,2
300	370	307	324,0	75	82,5	3,6
350	430	350	363,0	90	97,5	7,0
400	482	400	413,0	100	107,5	9,0
500	585	500	520,0	120	127,5	14,0

## Fix flange

Description: Fix flange  
 Connection acc. : DIN/ISO 2501 – cylindrical bonding  
 Material : Epoxy  
 Diameter: DN 25 – 300  
 Pressure class: PN 10 up to DN 300

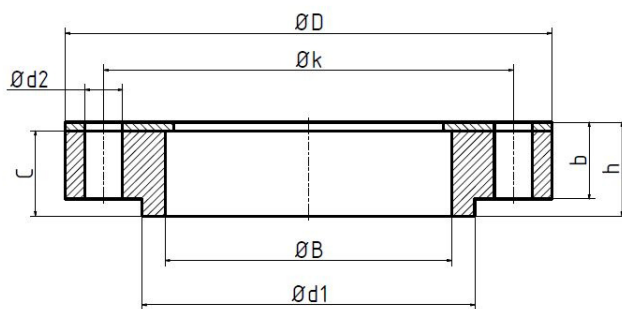

DN	Ø D [mm]	Ø B [mm]	Ø d1 [mm]	Ø k [mm]	C [mm]	h [mm]	b [mm]	Ø d2 [mm]	No.	Bolts	Weight ca.[kg]
25	115	34	52	85	30	37,5	22,5	14	4	M12	0,4
40	150	48	68	110	35	42,5	27,5	18	4	M16	0,7
50	165	60	89	125	45	52,5	32,5	18	4	M16	1,0
65	185	73	97	145	45	52,5	32,5	18	4	M16	1,4
80	200	89	110	160	45	52,5	32,5	18	8	M16	1,8
100	220	114	147	180	45	52,5	42,5	18	8	M16	2,0
125	250	135	161	210	45	52,5	42,5	18	8	M16	2,6
150	285	168	195	240	45	52,5	42,5	22	8	M20	3,0
200	340	219	238	295	50	57,5	40,5	22	8	M20	5,0
250	395	273	315	350	65	72,5	47,0	22	12	M20	7,5
300	445	324	365	400	75	82,5	46,5	22	12	M20	10,0

## Blind flange

Description: Blind flange  
 Connection acc. : DIN/ISO 2501  
 Material : Epoxy  
 Diameter: DN 25 - 500  
 Pressure class: PN 10 up to DN 300; PN 6 up to DN 500

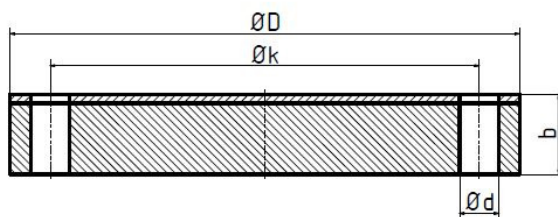

DN	$\varnothing D$ [mm]	$b$ [mm]	$\varnothing k$ [mm]	$\varnothing d$ [mm]	No.	Bolts	Weight ca.[kg]
25	115	22	85	14	4	M 12	0,3
40	150	30	110	18	4	M 16	0,8
50	165	30	125	18	4	M 16	1,0
65	185	30	145	18	4	M 16	1,2
80	200	30	160	18	8	M 16	1,4
100	220	30	180	18	8	M 16	2,3
125	200	40	210	18	8	M 16	3,1
150	285	40	240	22	8	M 20	3,9
200	340	40	295	22	8	M 20	4,9
250	395	45	350	22	12	M 20	7,6
300	445	45	400	22	12	M 20	11,2
350	505	50	460	22	16	M 20	16,0
400	565	50	515	26	16	M 24	20,0
450	615	55	565	26	20	M 24	26,0
500	670	60	620	26	20	M 24	33,0

## Galvanized steel loose flange

Description: Galvanized steel loose flange  
 Connection acc. : DIN/ISO 2501  
 Material : St 37 galvanized  
 Diameter: DN 25 - 800  
 Pressure class: PN 16 up to DN 150; PN 10 from DN 200 to DN 800

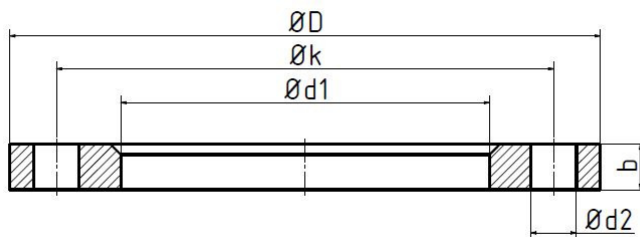

DN	ø D [mm]	ø d1 [mm]	b [mm]	ø k [mm]	ø d2 [mm]	No.	Bolts	Weight ca.[kg]
25	115	36	16	85	14	4	M 12	1,1
40	150	54	16	110	18	4	M 16	1,8
50	165	65	16	125	18	4	M 16	2,1
80	200	94	18	160	18	8	M 16	3,2
100	220	119	18	180	18	8	M 16	3,5
150	285	173	18	240	22	8	M 20	5,2
200	340	225	20	295	22	8	M 20	7,5
250	395	279	22	350	22	12	M 20	9,8
300	445	325	26	400	22	12	M 20	14,4
400	565	426	32	515	26	16	M 24	25,0
450	615	470	35	565	26	20	M 24	30,9
500	670	533	38	620	26	20	M 24	39,3
600	780	618	44	725	30	20	M 27	56,4
700	895	721	50	840	30	24	M 27	79,8
800	1015	824	56	950	33	24	M 30	111,9

### **PP/Steel loose flange**

Description: PP/Steel loose flange, drilled acc. DIN 2501, black  
 Connection acc. : DIN/ISO 2501  
 Material : Fibreglass reinforced PP with steel reinforcement  
 Diameter: DN 25 - 500  
 Pressure class: PN 16 up to DN 150; PN 10 from DN 200 to DN 500

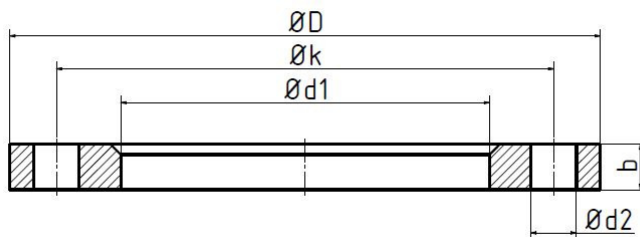

DN	ø D [mm]	ø d1 [mm]	b [mm]	ø k [mm]	ø d2 [mm]	No.	Bolts	Weight ca.[kg]
25	115	42	16	85	14	4	M 12	0,5
40	150	62	18	110	18	4	M 16	0,8
50	165	78	18	125	18	4	M 16	0,9
65	185	92	18	145	18	4	M 16	1,2
80	200	108	20	160	18	8	M 16	1,4
100	220	128	20	180	18	8	M 16	1,7
125	250	158	24	210	18	8	M 16	2,3
150	285	178	24	240	22	8	M 20	3,6
200	340	237	24	295	22	8	M 20	4,6
250	395	288	30	350	22	12	M 20	7,2
300	445	338	34	400	22	12	M 20	9,5
400	565	430	44	515	26	16	M 24	19,8
500	675	533	44	620	26	20	M 24	24,7

### GF-UP loose flange

Description: GF-UP loose flange, drilled acc. DIN 2501, black  
 Connection acc. : DIN/ISO 2501  
 Material : Fibreglass reinforced UP  
 Diameter: DN 25 - 300  
 Pressure class: PN 10 up to DN 300

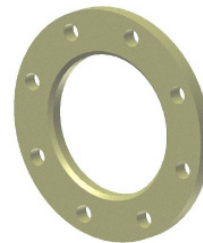
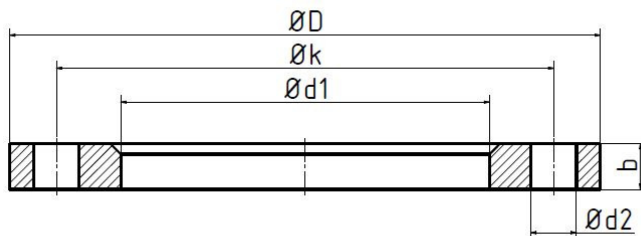

DN	ø D [mm]	ø d1 [mm]	b [mm]	ø k [mm]	ø d2 [mm]	No.	Bolts	Weight ca.[kg]
25	115	36	14	85	14	4	M 12	0,2
40	150	56	16	110	18	4	M 16	0,4
50	165	65	18	125	18	4	M 16	0,5
80	200	94	22	160	18	8	M 16	0,7
100	220	119	24	180	18	8	M 16	0,9
150	285	173	30	240	23	8	M 20	1,6
200	340	225	32	295	23	8	M 20	2,3
250	395	280	34	350	23	12	M 20	2,8
300	445	329	36	400	23	12	M 20	3,4

Physical properties of cast epoxy pipes:

	Temperature 24°C		Temperature 90°C
	MPa		MPa
<b>Axial Tensile – ASTM D 2105</b>			
Ultimate Stress	71		53
Design Stress	17,8		13,3
Modulus of Elasticity	12 548		8136
<b>Poisson's Ratio</b>	0,38		
<b>Axial Compression - ASTM D 695</b>			
Ultimate Stress	230		134
Design Stress	57,4		33,4
Modulus of Elasticity	8 687		4 137
<b>Beam Bending - ASTM D 790</b>			
Ultimate Stress	158,6		110
Design Stress	19,8		13,8
Modulus of Elasticity	10 000		6 630
<b>Hydrostatic Burst - ASTM 1599</b>			
Ultimate Hoop Tensile Stress	234		300
Hydrostatic Design - ASTM 2992 Procedure A – Hoop tensile Stress Cyclic 150 x 10 <sup>6</sup> Cycles	DN 50- 80	64,9	39,9
	DN 100- 500	89,9	57,8
<b>Coefficient of linear Thermal expansion - ASTM D 696</b>	1,5 x 10-5 mm/mm/°C		
<b>Specific Gravity ASTM D 177</b>	1,8		
<b>Hazen-Williams Flow Factor</b>	150		

## Operating pressure rating for pipe systems

	up to 90°C
DN 50	16 bar
DN 80	16 bar
DN 100	16 bar
DN 150	16 bar
DN 200	10 bar
DN 250	10 bar
DN 300	10 bar
DN 350	10 bar
DN 400	10 bar
DN 450	10 bar
DN 500	10 bar

## Flow rates and pressure loss for water $t = 10^\circ \text{C}$

	DN 50	DN 80	DN 100	DN 150	DN 200	DN 250	DN 300
v / m/s	Q l/ min	Q l/ min	Q l/ min	Q l/ min	Q l/ min	Q l/ min	Q l/ min
0,1	10,41	27,22	48,07	110,31	196,11	313,68	449,94
0,25	26,02	68,05	120,18	275,78	490,28	784,19	1124,86
0,5	52,05	136,09	240,36	551,56	980,55	1568,38	2249,72
0,75	78,07	204,14	360,53	827,34	1470,83	2352,57	3374,58
1	104,10	272,19	480,71	1103,12	1961,11	3136,75	4499,44
1,25	130,12	340,23	600,89	1378,90	2451,38	3920,94	5624,30
1,5	156,15	408,28	721,07	1654,68	2941,66	4705,13	6749,15
2	208,19	544,38	961,42	2206,25	3922,22	6273,51	8998,87
3	312,29	816,56	1442,13	3309,37	5883,32	9410,26	13498,31
4	416,39	1088,75	1922,84	4412,49	7844,43	12547,02	17997,74
5	520,48	1360,94	2403,55	5515,62	9805,54	15683,77	22497,18

## Recommended flow rate and volume flow for Fibercast cast pipes

DN 50	DN 80	DN 100	DN 150	DN 200	DN 250	DN 300
v / m/s	v / m/s	v / m/s	v / m/s	v / m/s	v / m/s	v / m/s
3	3	3	2,5	1,75	1,75	1,75
Q m <sup>3</sup> /h	Q m <sup>3</sup> /h	Q m <sup>3</sup> /h	Q m <sup>3</sup> /h	Q m <sup>3</sup> /h	Q m <sup>3</sup> /h	Q m <sup>3</sup> /h
18,74	48,994	86,528	165,47	205,92	329,359	472,441

## Span supports in m at different temperatures

	24°C	65°C	90°C
DN 50	3,84 m	3,66 m	3,47 m
DN 80	4,27 m	4,05 m	3,84 m
DN 100	4,85 m	4,60 m	4,36 m
DN 150	5,76 m	5,49 m	5,18 m
DN 200	6,28 m	5,94 m	5,67 m
DN 250	7,07 m	6,70 m	6,37 m
DN 300	7,65 m	7,28 m	6,89 m
DN 350	8,35 m	7,92 m	7,53 m
DN 400	8,90 m	8,44 m	8,01 m
DN 450	9,27 m	8,81 m	8,35 m
DN 500	9,57 m	9,08 m	8,63 m

Density in Kg/m <sup>3</sup>	2000	1500	1250	1000	750
Correction factor	0,84	0,9	0,95	1,00	1,07

Example: Density =1500 DN 150 65°C results in 5,94 m x 0,9 = 5,35 m span.

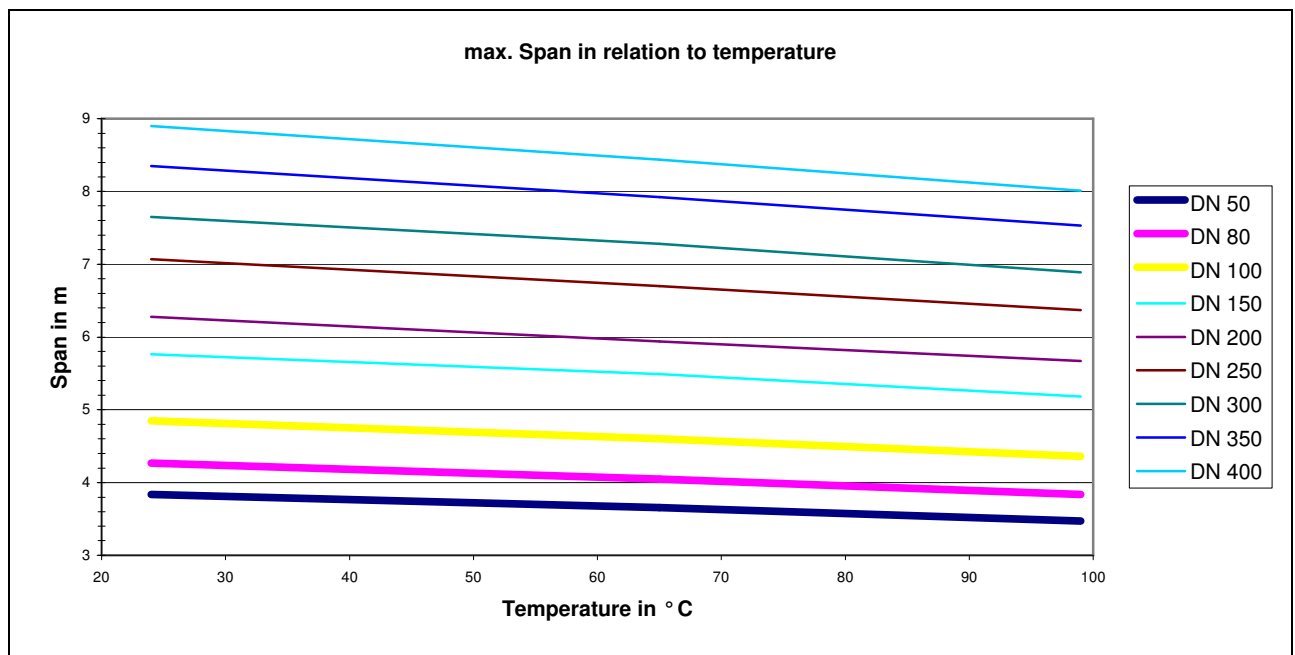

## Thermal expansion

The coefficient of thermal expansion is  $19,9 \times 10^{-6} \text{ m / (m x K)}$ .  
 Please find the results of calculation in the table below (line length 100 m).

$\Delta T$ in K	thermal expansion in mm pro 100 m
10	19,9
20	39,8
30	59,7
40	79,6
50	99,5
60	119,4
70	139,3
80	159,2
90	179,1
100	199
110	218,9
120	238,8
130	258,7

## Loop leg bends

Similar to the practise in standard pipe construction it is usually to use U-bends to compensate the thermal expansion. Often it is enough to have a change in direction. The following table gives you the minimum leg length (in m), which is required for the given expansion (in mm) for each diameter.

DN	Elongation in mm							
	25 mm	50 mm	75 mm	100 mm	125 mm	150 mm	200 mm	250 mm
50	1,2 m	1,7 m	2,0 m	2,3 m	2,6 m	2,8 m	3,2 m	3,6 m
80	1,6 m	2,1 m	2,5 m	2,9 m	3,2 m	3,4 m	4,0 m	4,4 m
100	1,8 m	2,4 m	2,9 m	3,3 m	3,6 m	3,9 m	4,5 m	5,0 m
150	2,1 m	2,9 m	3,4 m	3,9 m	4,4 m	4,8 m	5,4 m	6,0 m
200	2,9 m	3,7 m	4,4 m	4,9 m	5,4 m	5,9 m	6,6 m	7,3 m
250	3,3 m	4,3 m	5,0 m	5,6 m	6,2 m	6,6 m	7,5 m	8,3 m
300	3,7 m	4,8 m	5,5 m	6,2 m	6,8 m	7,3 m	8,3 m	9,1 m
350	4,1 m	5,2 m	6,1 m	6,8 m	7,4 m	8,0 m	9,0 m	9,9 m
400	4,5 m	5,7 m	6,6 m	7,3 m	8,0 m	8,6 m	9,7 m	10,7 m
450	5,1 m	6,3 m	7,3 m	8,1 m	8,8 m	9,4 m	10,6 m	11,6 m
500	5,6 m	6,9 m	7,9 m	8,7 m	9,5 m	10,2 m	11,4 m	12,4 m